

Cenomic Optima.
**Your next-
generation full-
volume bead mill.**

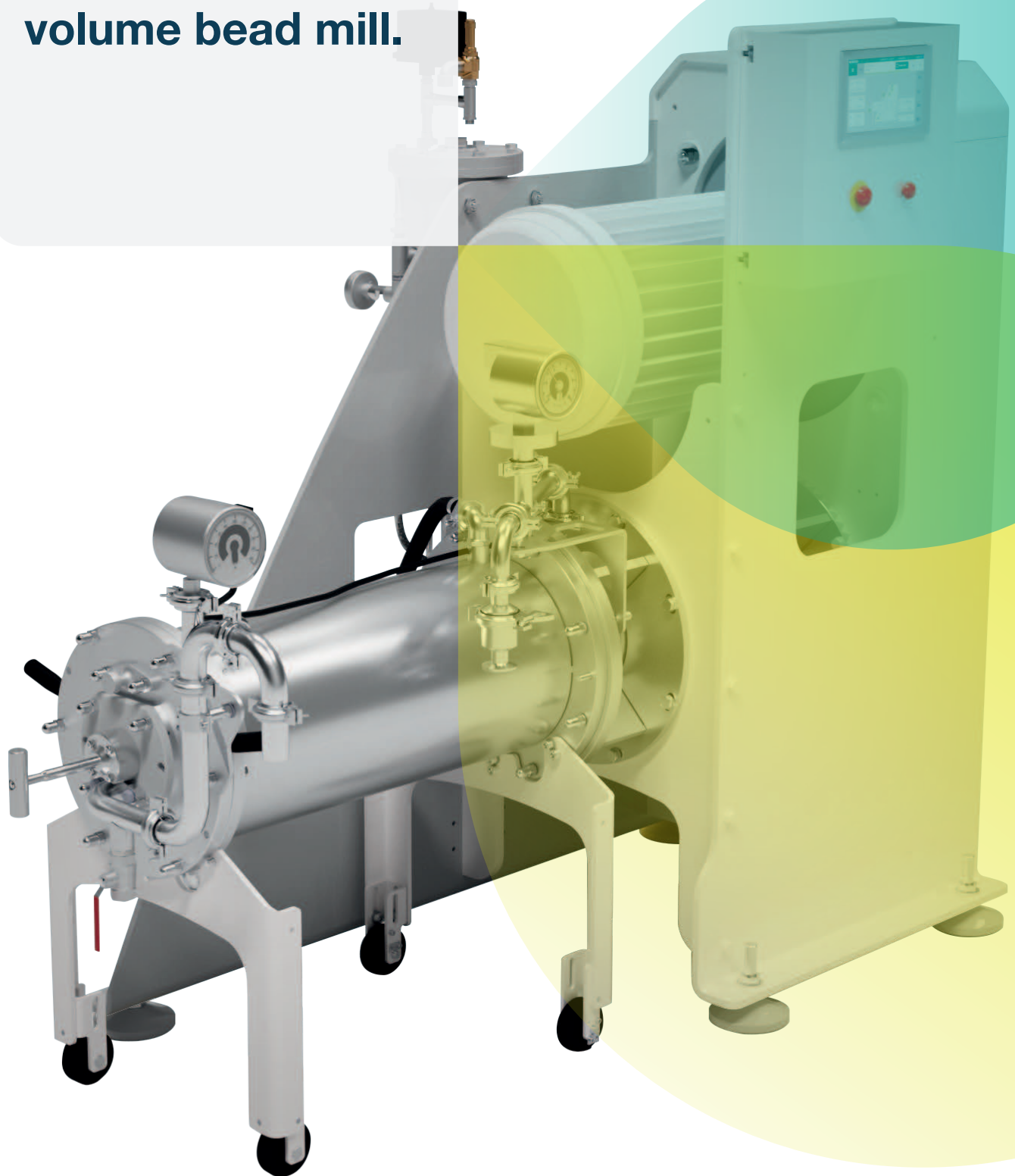

Next generation full-volume agitated bead mill. **25%-50% higher productivity.**

The new Bühler Cenomic Optima takes agitated bead mill technology to the next level, bringing you higher flow rates, higher power inputs and improved cooling to deliver up to 25%-50% higher productivity overall.

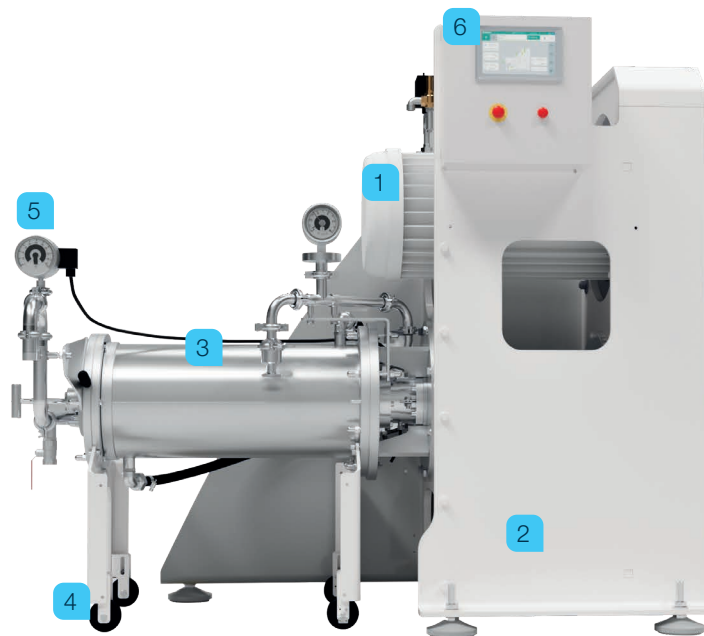

- | | | | |
|---|------------------------------------------|---|------------------------------------------------|
| 1 | Higher power input for faster processing | 4 | Moveable process chamber |
| 2 | Proven Cenomic machine frame | 5 | Product outlet with product temperature sensor |
| 3 | Improved grinding chamber geometry | 6 | Different control options available |

Benefits

- 25%-50 higher productivity to reach your desired specific energy faster
- Expect higher flow rates and improved efficiency with the same footprint
- Designed to keep products below temperature limits
- Minimize blockages and hydraulic packing, for smoother production

Introducing a series of technological advances. **For faster, smoother wet-grinding.**

The re-engineered Cenomic Optima offers a range of innovative technological improvements to speed up your wet grinding operation without compromising product quality.

Additional discs

Clever configuration within the chamber allows the Cenomic Optima to offer 37.5% more grinding disc surface, for more efficient bead activation.

More powerful drive unit

The new 30 kW drive unit allows you to increase the power input and thus reach the required specific energy for optimal grinding faster. This can improve productivity by up to 25%-50%.

Ceramic inner liner

A new ceramic liner ensures your products stay cooler during grinding. This allows you to use the higher power input without breaching the product's temperature limit.

Larger screen diameter

A larger screen diameter reduces pressure within the chamber and enables at least 25%-50% faster flow rates. This speeds up your process and avoids unwanted hydraulic packing.

Serving a diverse range of applications.

The Cenomic Optima is designed for grinding low to medium viscosity products from submicron (100nm) to micron (50µm) particle sizes, in a broad range of applications:



Printing inks

Sheet-fed, web offset, screen, inkjet, packaging and security inks



Solar

Silver, aluminum, titanium dioxide and glass solder pastes.

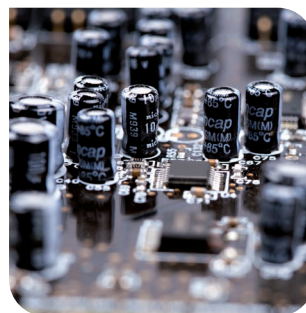

Electronics

Glass, phosphor and metal pastes, and printed circuit boards.



Other

Cosmetics, carbon nano tubes, lubricants, sealing pastes and artist colors.

Evolution of a proven mill. **Optimal performance from the same footprint.**

Building on decades of reliable service, the Cenomic Optima offers a powerful range of improvements within the same machine footprint, making it easy for you to replace or upgrade existing machines.

Bühler consulting and engineering services can work with your team to help you plan the best possible implementation for your application.

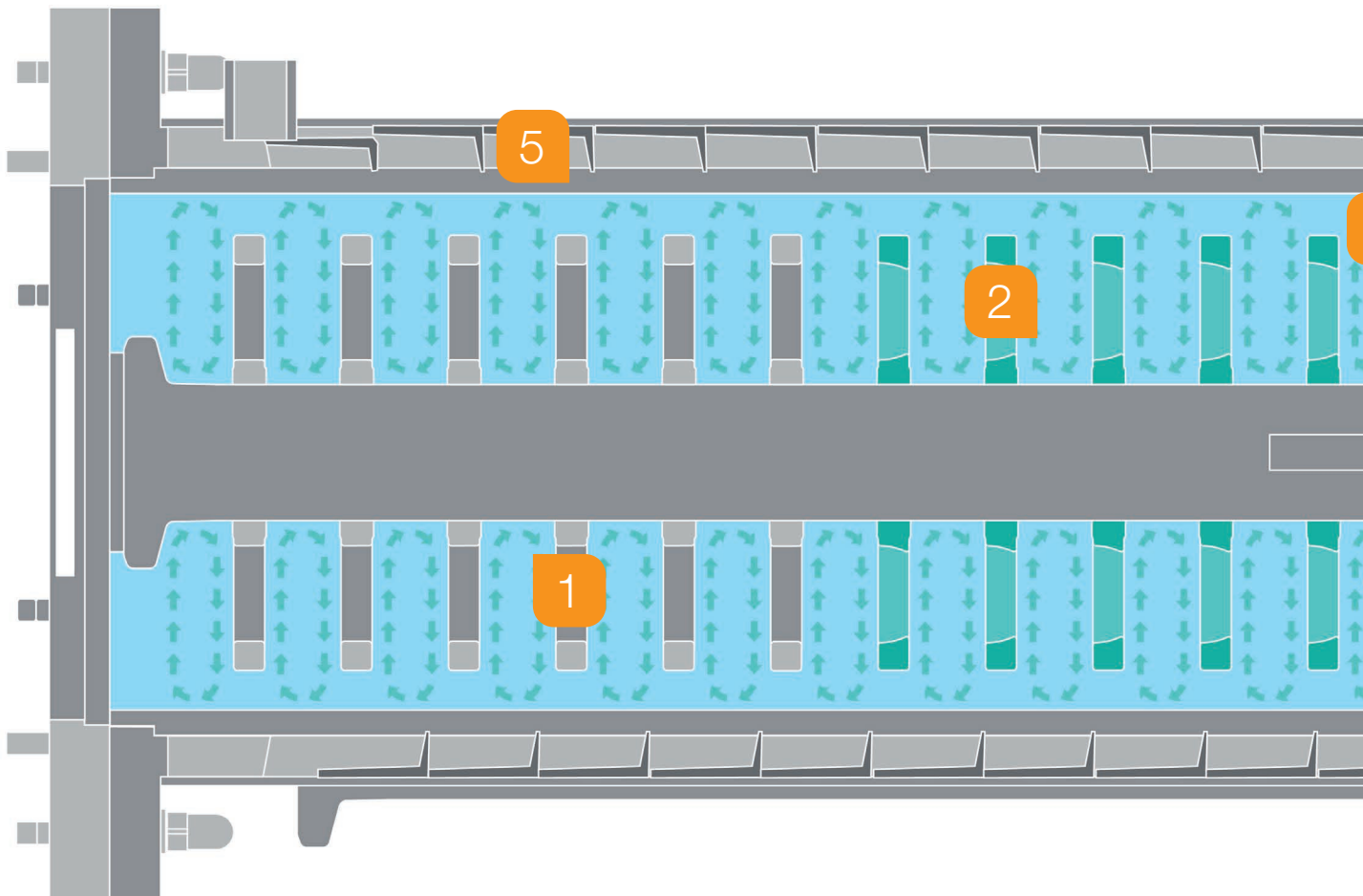

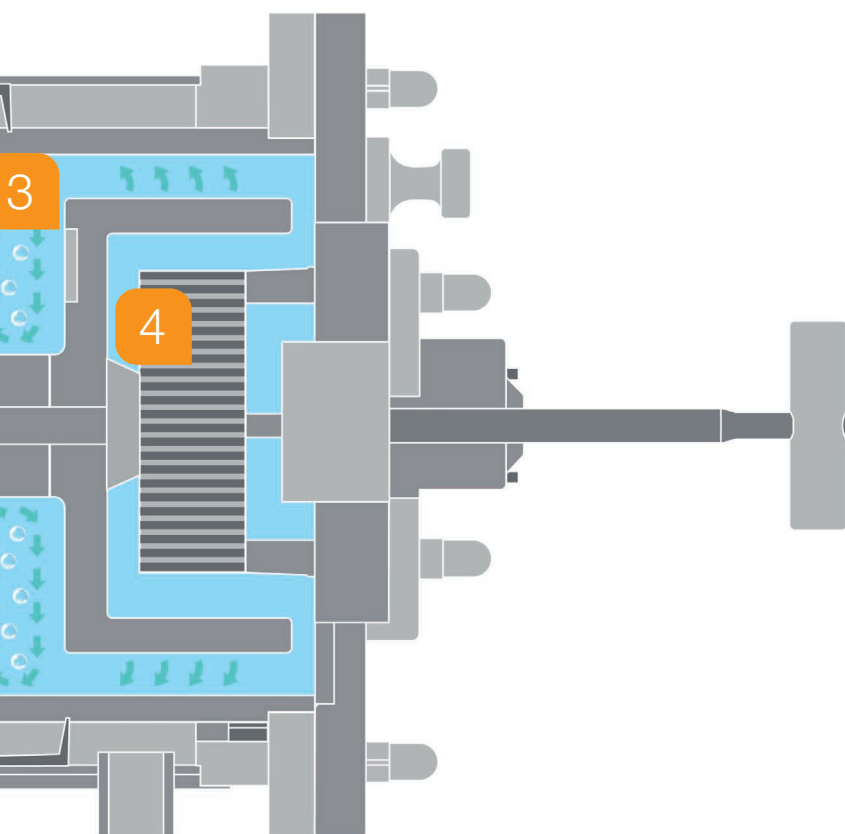

Available as an Upgrade kit

As well as new machines, Genomic Optima can be delivered as an upgrade kit to your existing Genomic 3, 20 liter machine (with other models soon to be released).

The upgrade kit includes:

- New discs
- Ceramic inner liner
- Larger screen
- Optional 30 kW drive unit

- 1 More discs within the same chamber**
Deliver better bead activation.
- 2 Reverse feeding EcoMizer agitator discs**
Reduce bead compression.
- 3 Improved circulation**
Speeds up the grinding process and eradicates hydraulic packing.
- 4 Larger screen diameter**
Enables higher flow rates with minimal maintenance.
- 5 Ceramic inner liner**
For better cooling.

Cenomic Optima in action.

Cooler, faster and more efficient.



Solvent-based packaging ink

With up to **nine times higher thermal conductivity compared to steel** the ceramic inner liner can cope with a higher power input without over-heating your products.

This case study with solvent-based packaging ink shows that with a stainless steel inner liner, it was almost impossible to reach the required target quality of < 10 microns without exceeding the temperature limit. With the ceramic inner liner, the target quality can be achieved with a product temperature almost 7°C lower. You could even increase rotor and pump speeds for higher productivity.



Solvent-based wood lacquer

Using the same ceramic inner liner in the Cenomic Optima and the original Cenomic 3, the new machine **delivers a 25% higher flow rate**, producing an additional 140 kg every hour.

The redesigned process chamber of the Cenomic Optima achieves better bead activation, delivering improved product quality with similar process parameters. You could even increase productivity without reaching the product's temperature limit.



Water-based paper coating

Overall, the Cenomic Optima with its ceramic inner liner delivers a **40% higher flow rate** compared to an original Cenomic machine with a steel inner liner at the same rotor speed.

In this case study with water-based paper coating, the Cenomic Optima can accept a 39% higher power input. Thanks to the high cooling capability of the ceramic inner liner, the product temperature is 13°C lower compared to the original Cenomic 3. This allows an increase in productivity by at least 40%.



Technical data.

Cenomic Optima.

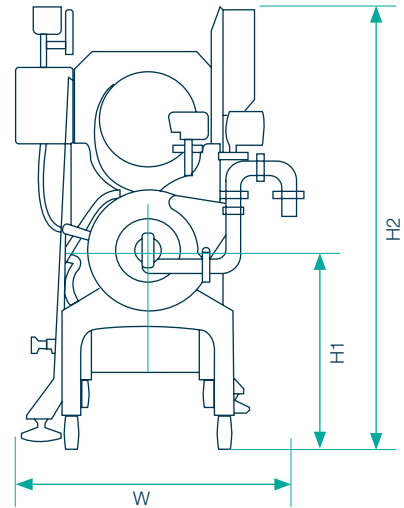
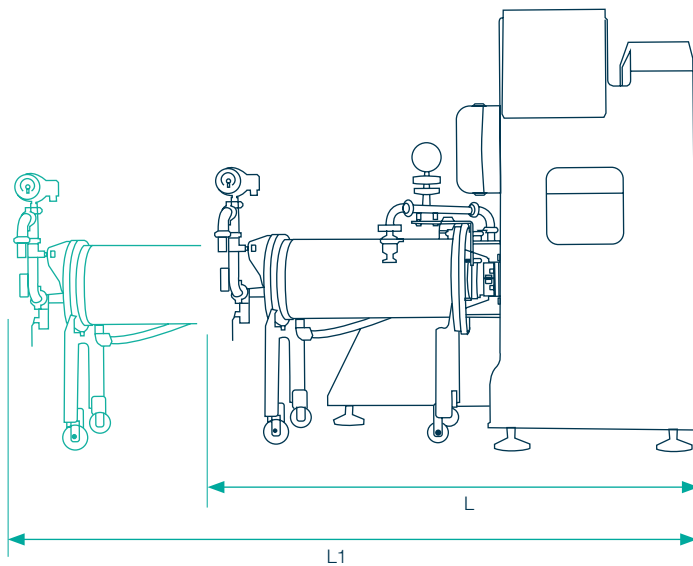

		Cenomic Optima 3	Cenomic Optima 6	
Drive		30 kW	45 kW	
EcoMizer disc		DraisResist (standard) DraisElast - PU Silicon carbide Oxide ceramics	DraisResist (standard) DraisElast - PU Silicon carbide Oxide ceramics	
Stator tube		Silicon carbide (standard) DraisResist Stainless steel DraisElast Oxide ceramics	Silicon carbide (standard) DraisResist Stainless steel DraisElast Oxide ceramics	
Inner liner exchangeable		Yes	Yes	
Volume DraisResist (metal) / Silicon carbide (ceramic)	Volume inner liner Active chamber volume	30 l 20 l	68 l 47 l	Cenomic Optima 15 and 30 will follow (Active chamber volumes 117 l, 226 l)
Volumes DraisElast (metal-free)	Volume inner liner Active chamber volume	29 l 18 l	65 l 45 l	
Volumes DraisElast (metal-free) / DraisResist (metal)	Volume inner liner Active chamber volume	29 l 19 l	64 l 47 l	
SuperScreen		Stainless steel Ceramic	Stainless steel Ceramic	
Control system		Comfort Comfort-Touch (Asian only) Premium Premium PLUS	Comfort Comfort-Touch (Asian only) Premium Premium PLUS	
Execution		Non-Ex / Ex	Non-Ex / Ex	
Bead size		0.3-2 mm	0.3-2 mm	
Tip speed		~ 9.5-13 m/s	~ 8-13 m/s	
In-situ cleaning device		Standard	Optional	
Dimensions	Length - L Length - L1 Width - W Height 1 - H1 Height 2 - H2 Weight ¹	1810 mm 2520 mm 935 mm 595 mm 1540 mm 1230 kg	2200 mm 3300 mm 910 mm 620 mm 1800 mm 2200 kg	

¹ Without control cabinet, without beads.
All data are approximate. Technical alterations reserved.

Bühler AG

CH-9240 Uzwil
Switzerland

T +41 71 955 11 11
F +41 71 955 31 49

grinding.dispersing@buhlergroup.com
buhlergroup.com

GenomicOptima_en_03/22