



Vitaris combicleaner MTKC.



Excellent sieving and separation selectivity.

The Vitaris combicleaner MTKC offers a perfectly coordinated cleaning system with a small footprint. The pre-wired modules can be assembled quickly and easily. Quick-clamping devices and good access to the machine mean that operating times can be kept at a constantly high level. The machine is designed so that dynamic drives as well as the airflows of all modules operate independently of each other. This reduces the dynamic forces on the building and ensures high cleaning performance.

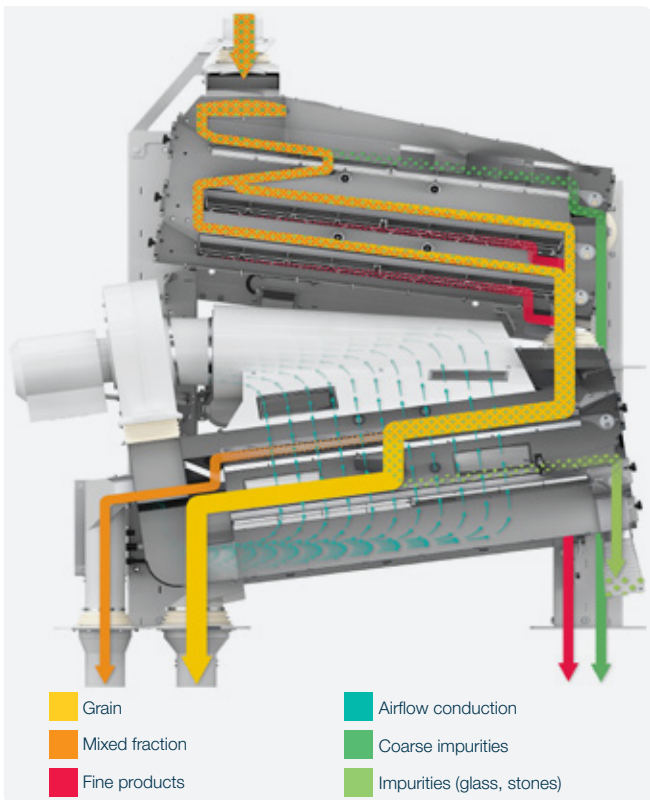

The modular **Vitaris** cleaning system.



The main benefits for you:

- Plug-and-Play system facilitates installation
- High product quality thanks to excellent selectivity
- Optimally coordinated process with minimum energy and space requirements
- Constantly high operating times

Vitaris combicleaner MTKC.

Matches your requirements.

Overview of technical data:

Model	Throughput Cleaning t/h	Width Aspiration channel m	Motor rating kW	Weight (approx.) kg
MTKC-60	2 - 12	0,5	2,2	1600
MTKC-120	12 - 24	1	4	2375

Model	Dimensions mm					
	A	B	C	D	E	F
MTKC-60	2470	1920	1340	2435	3210	3435
MTKC-120	2470	1920	1980	2565	3210	3455

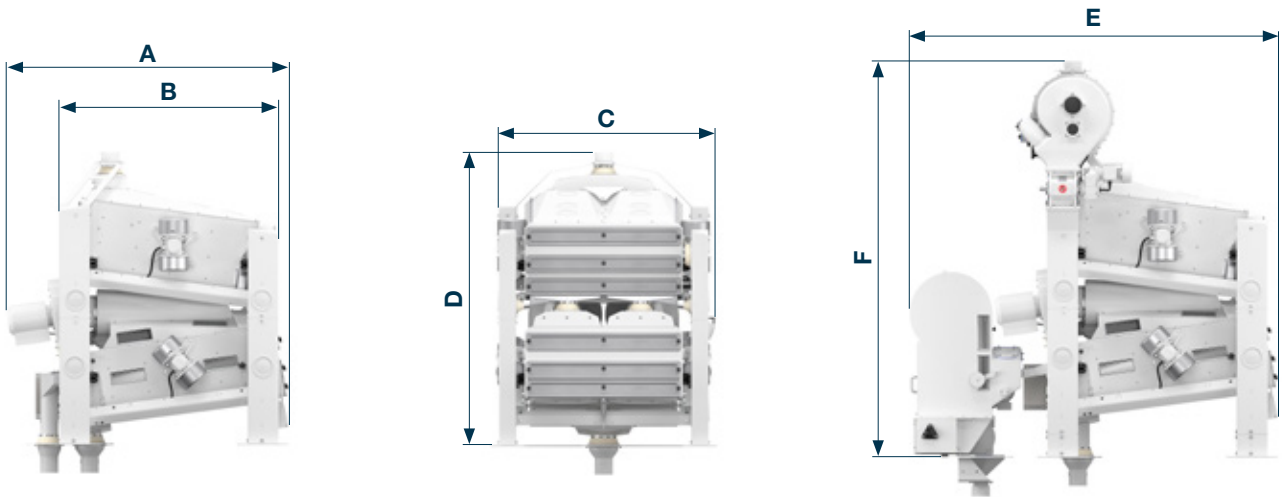

Examples of combinations in the Vitaris cleaning system:



Vitaris combicleaner
MTKC.



Vitaris combicleaner
MTKC.
+
Air-recycling
aspiration channel
MVSS.



Vitaris combicleaner
MTKC.
+
Air-recycling aspirator
MVST.



Vitaris combicleaner
MTKC.
+
Air-recycling aspirator
MVST.
+
Air-recycling
aspiration channel
MVSS.



Bühler AG

CH-9240 Uzwil, Switzerland T: +41 71 955 11 11
buhlergroup.com F: +41 71 955 66 11

